

PRODUCT SPECIFICATIONS

Elkay Outdoor ezH2O® Upper Bottle Filling Station Bi-Level Pedestal, Non-Filtered Non-Refrigerated. Features shall include 316 Stainless, Heavy Duty Vandal Resistant, Laminar Flow. Furnished with Vandal Resistant bubbler. Mechanical Front Bubbler Button activation. Product shall be Floor Mount/Freestanding, for Outdoor applications, serving 2 station(s). Unit shall be lead-free design which is certified to NSF/ANSI 61 & 372 (lead free) and meets Federal and State low-lead requirements.

Special Features:	316 Stainless, Heavy Duty Vandal Resistant, Laminar Flow
Finish:	Beige (BGE), Black (BK), Blue (BLU), Brown (BRN), Evergreen (EVG), Gray (GRY), Orange (ORN), Powder Coat (12 Color Options), Purple (PUR), Red (RED), Terracotta (TER), White (WHT), Yellow (YLW)
Power:	No Electrical Required
Bubbler Style:	Vandal Resistant
Activation by:	Mechanical Front Bubbler Button
Mounting Type:	Floor Mount/Freestanding
Chilling Capacity:	Non-refrigerated
Dimensions (L x W x H):	14" x 31" x 64"
Approx. Shipping Weight:	147 lbs.
Installation Location:	Outdoor
No. of Stations Served:	2

**When used in non-temperature controlled environments, unit(s) must be adequately winterized and/or protected from extreme heat to prevent damage where climates dictate.

Special Note: Bottle Filler Stations 1 (Upper), Bubbler Stations 1 (Low), Choose from 12 color options

- Mechanically-Activated bubbler continues to supply water in event of service disruptions.
- Laminar flow provides clean fill with minimal splash.
- Base material constructed from marine-grade 316 stainless steel provides the ultimate corrosion protection from even the most corrosive elements.



Included with Product: Outdoor Bottle Filler
Ships in one box.

A Century of Tradition and Quality. For more than 100 years, Elkay has been making innovative products and providing exceptional customer care. We take pride in offering plumbing products that make life easier, inspire change and leave the world a better place.



PRODUCT COMPLIANCE

- ADA & ICC A117.1
- ASME A112.19.3/CSA B45.4
- Buy American Act
- GreenSpec®
- NSF/ANSI 61 & 372 (lead free)



Complies with ADA & ICC A117.1 accessibility requirements when installed according to the requirements outlined in these standards. Installation may require additional components and/or construction features to be fully compliant. Consult the local Authority Having Jurisdiction if necessary.

[Installation Instructions \(PDF\) - 1000003685](#)

Warranty pertains to drinking water applications only. Non-drinking water applications are not covered under warranty.

[Warranty \(PDF\)](#)

PART: _____ QTY: _____

PROJECT: _____



CONTACT: _____

DATE: _____

NOTES: _____

APPROVAL: _____

In keeping with our policy of continuing product improvement, Elkay reserves the right to change product specifications without notice. Please visit elkay.com for the most current version of Elkay product specification sheets. This specification describes an Elkay product with design, quality, and functional benefits to the user. When making a comparison of other producers' offerings, be certain these features are not overlooked.

Optional Accessories		
LK4471LHB	Locking Hose Bib Spec Sheet (PDF)	
97890C	Accessory - Direct Bury Adaptor Spec Sheet (PDF)	
4481FP	Outdoor Bottle Filler Foot Pedal Accessory Spec Sheet (PDF)	

In keeping with our policy of continuing product improvement, Elkay reserves the right to change product specifications without notice. Please visit elkay.com for the most current version of Elkay product specification sheets. This specification describes an Elkay product with design, quality, and functional benefits to the user. When making a comparison of other producers' offerings, be certain these features are not overlooked.

**MOUNTING INSTRUCTIONS and
PLUMBING CONNECTIONS**

Provide solid, well-drained surface to mount pedestal fountain (concrete pad recommended) with adequate support (300 lb. load minimum). (6) 3/8" minimum fasteners (not included) should be attached firmly to mounting surface in order to secure unit. (Refer to rough-in diagram)

Locate and install plumbing through ground as required.

NOTE: Unit is not furnished with service valve.

Position pedestal over plumbing and secure base to fasteners. Remove access panels and connect supply and water lines. Turn on water supply and check for leaks. Reassemble access panels to pedestal.

Trap and service stop not included

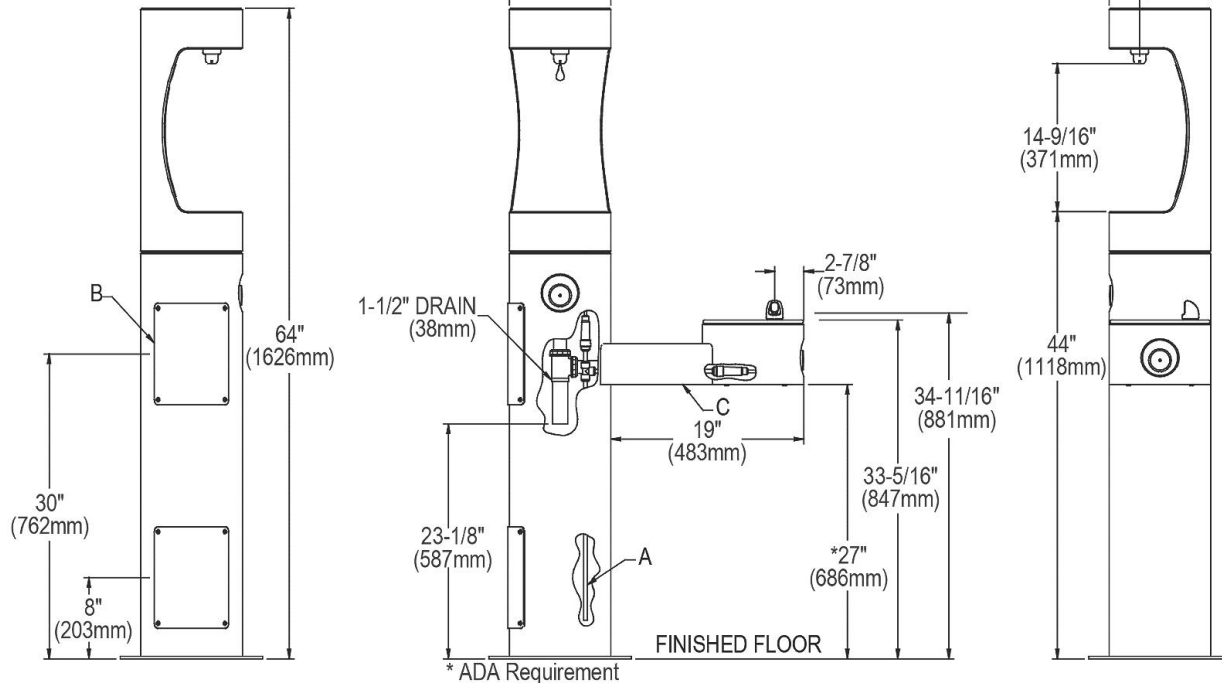

A = 3/8" O.D. Unplated copper tube connect. Shut off valve by others.
B = Access panel(8" x 10").
C = Removable bottom cover.

OPERATING PRESSURES:
Supply water 20 – 105 psi maximum

TOP VIEW

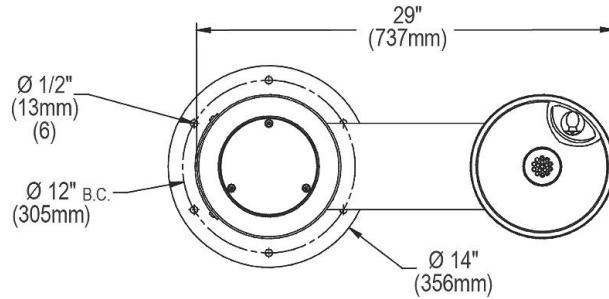

FRONT & SIDE VIEWS

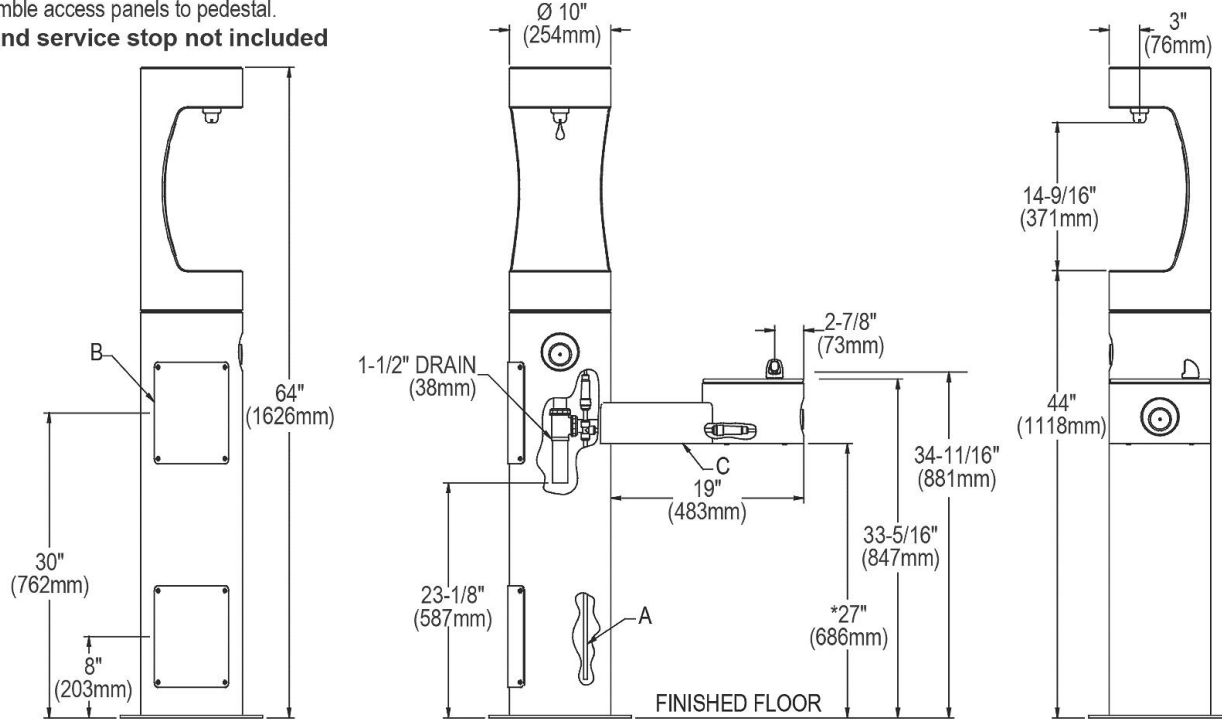

* ADA Requirement

In keeping with our policy of continuing product improvement, Elkay reserves the right to change product specifications without notice. Please visit elkay.com for the most current version of Elkay product specification sheets. This specification describes an Elkay product with design, quality, and functional benefits to the user. When making a comparison of other producers' offerings, be certain these features are not overlooked.

PRODUCT SPECIFICATIONS

Outdoor Bottle Filler Foot Pedal Accessory. Overall dimensions are 7-7/16" x 5" x 12-3/4".

Finish:	Beige (BGE), Black (BK), Blue (BLU), Brown (BRN), Evergreen (EVG), Gray (GRY), Orange (ORN), Purple (PUR), Red (RED), Terracotta (TER), White (WHT), Yellow (YLW)
Dimensions:	7-7/16" x 5" x 12-3/4"
Shipping Weight:	7 lbs.

Special Note: Need product compatibility info? Find model compatibility guide under the product downloads section.

- Convenient foot activation for healthier, hands-free bottle filling.
- Activates bottle filler only and will not activate attached fountains. Pedal will not deactivate the bottle filler push button.
- Attaches to lower access panel opening for secure connection and easy installation.
- Powder-coated exterior over Type 316 stainless steel provides protection from the elements.
- Available in 12 finishes to coordinate with outdoor tubular bottle filling stations.
- Compatible with select outdoor tubular bottle filling stations.



A Century of Tradition and Quality.

For more than 100 years, Elkay has been making innovative products and providing exceptional customer care. We take pride in offering plumbing products that make life easier, inspire change and leave the world a better place.



Product Compliance: ASME A112.18.1/CSA B125.1
NSF 372 (lead free)
NSF 61

[Installation Instructions \(PDF\) - 1000006191](#)

[Installation Instructions \(PDF\) - Outdoor Foot Pedal Compatibility Guide](#)

PART: _____ QTY: _____

PROJECT: _____

CONTACT: _____

DATE: _____

NOTES: _____

APPROVAL: _____

In keeping with our policy of continuing product improvement, Elkay reserves the right to change product specifications without notice. Please visit elkay.com for the most current version of Elkay product specification sheets. This specification describes an Elkay product with design, quality, and functional benefits to the user. When making a comparison of other producers' offerings, be certain these features are not overlooked.

Parts List

ITEM NO.	PART NO.	DESCRIPTION
1	1000006138	ASSY, 4481 FP FOOT ACTIVATION
NS	28308C	WASHR-SPACER 2.00 O.D.
NS	40045C	NUT-HEX 1-5/16"
NS	10031C	1-1/8-24 RETAINING NUT
NS	1000004135	REGULATOR - HIGH FLOW WRAS
6	50985C	HOLDER-REGULATOR
7	45663C	SLEEVE - PUSH BUTTON GUIDE
8	45960C	BUTTON - PUSH W/O HOLE
9	55994C	TUBE-POLY 1/4X.040 WALL
10	1000004069	STRAINER-IN LINE WRAS
11	62223C	TUBE-CU 3/8 X 4.75 (1-P117)
12	70852C	FTTNG TEE - 3/8
13	70745C	FTTNG-UNION-3/8 X 1/4 UNION
14	56307C	TUBE-POLY 3/8X.062 WALL
15	50090C	INSULATOR-ARMAFLEX
16	75672C	SCREW-CAP #6-32
17	101461040560	INSULATOR-TUBE 3/8-3/16 BULK

NS = Not Shown

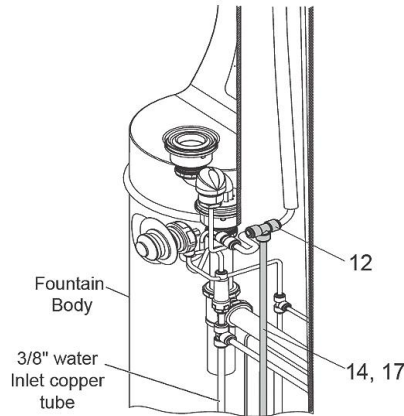
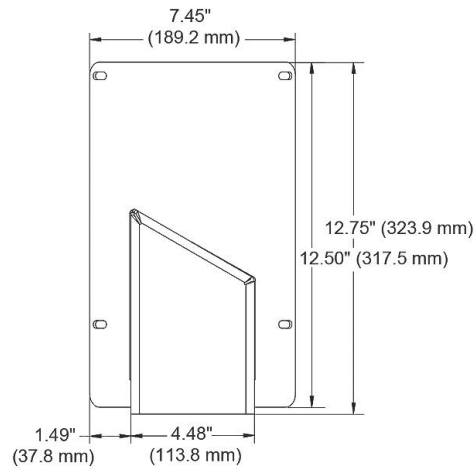

Upper Fountain Bottle Filler Internal View

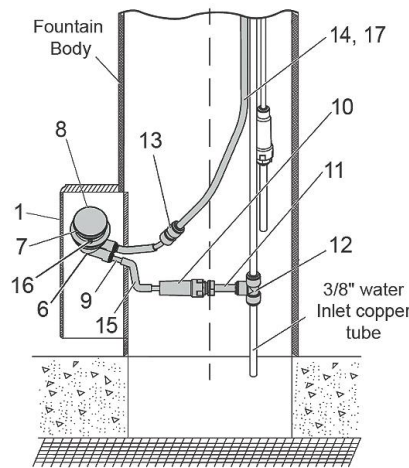
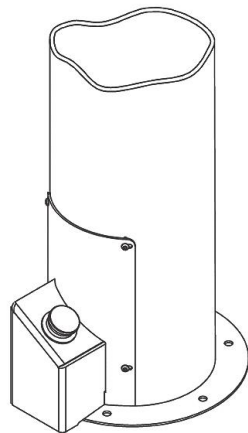
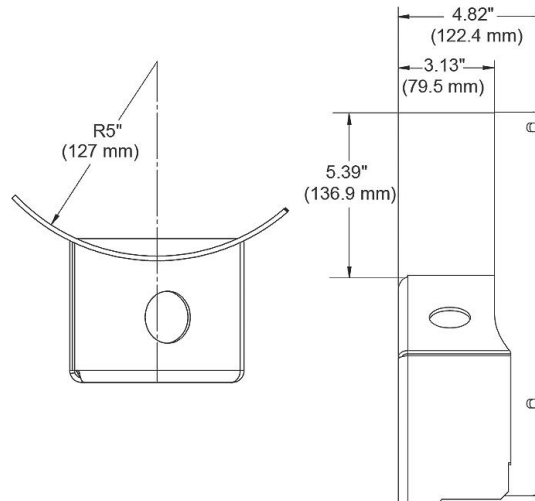

Lower Fountain Internal View

In keeping with our policy of continuing product improvement, Elkay reserves the right to change product specifications without notice. Please visit elkay.com for the most current version of Elkay product specification sheets. This specification describes an Elkay product with design, quality, and functional benefits to the user. When making a comparison of other producers' offerings, be certain these features are not overlooked.